

Solenoid Control Valve

The Singer Single Solenoid Control Valve is used for remote on/off control via SCADA, IoT, or local controller.

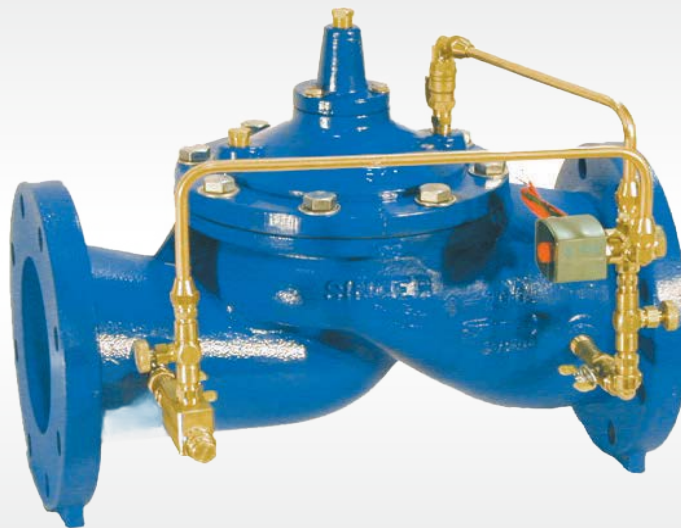

TECHNICAL GUIDE: **AVH1.16**

Applications

Potable water
Pressure control
Municipal
Mining Applications
Irrigation Applications

Product Attributes

Positive, drip-tight shut-off
Simple, on-off operation
Globe or angle style body

Approvals/Standards

AS 5081:2008
Flanges to AS/NZS 4087 Fig. B5
Coating complies with AS/NZS 4158

Quality:

ISO 9001:2015 Quality
Management Systems



Licence Number:
WMK/SMK26726

The Solenoid Control Valve responds to an electrical signal to provide two-position (On/Off) operation. The solenoid either admits inlet pressure into the main valve operating chamber or releases pressure from the operating chamber. A variety of voltage options are available and solenoids can be normally open or normally closed.

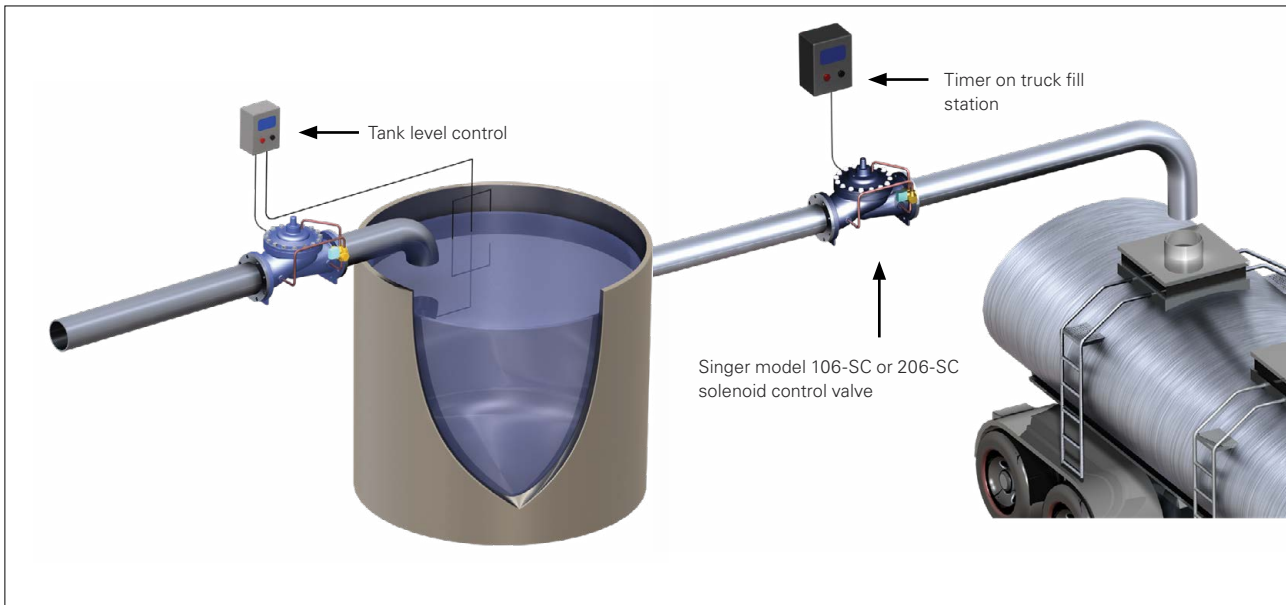

FIG. 1 Typical application

The solenoid control valve provides on-off position operation. The solenoid either admits inlet pressure into the main valve operating chamber or releases pressure from the operating chamber. The pilot system is usually piped to discharge at the valve outlet, but can be piped to discharge to drain (atmosphere). This valve is available either with the main valve closed when the solenoid is de-energised (NC - Normally Closed) or with the main valve open when the solenoid is de-energised (NO- Normally Open). (NC or NO refers to the main valve, not the solenoid.)

STANDARD MATERIALS

Standard materials for pilot system components are:

- ASTM B62 bronze or ASTM B-16 brass
- Stainless steel trim
- Standard solenoid coil is rated as NEMA 1, 2, 3, 3S, 4 and 4X, combination general purpose and watertight
- Other voltages, ratings and constructions are available, consult with Hygrade.

SELECTION SUMMARY

1. Select the valve with sufficient capacity, using the allowable operating pressure drop across the valve.
2. If the outlet pressure is less than 35% of the inlet pressure, check for cavitation.
3. Ensure the maximum working pressure rating of the valve exceeds the maximum operating pressure.
4. Continuous, "C", service up to 6 m/s is generally suitable.
5. Provide system maximum and minimum operating pressures, electrical voltage, etc for correct solenoid selection.
6. If control fluid is from a separate source, provide Hygrade with details.
 - a. For valve positioning - process control, see technical guide AVH1.15 Dual Solenoid Control Valve.
 - b. For two (2) stage opening or closing, consult with Hygrade.
 - c. Most pilot functions may be combined with the model SC, consult Hygrade.

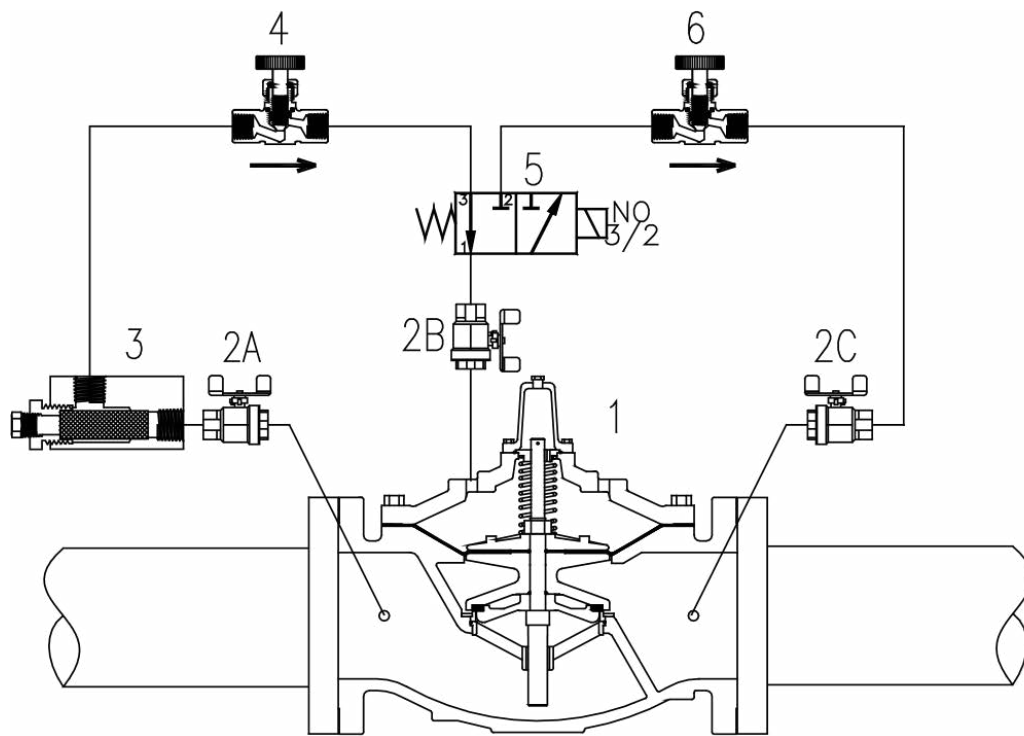

FIG. 2 Schematic A-0593C

SCHEMATIC DRAWING

1. Main Valve - 106-PG or 206-PG
2. Isolating Valves - 2A, 2B, 2C - (optional on 80 mm and smaller).
3. Strainer - 40 mesh stainless steel screen
4. Closing Speed Control - model 852-B (optional on 80 mm and smaller).
5. Solenoid Pilot Valve - 3 way - 120 VAC / 60 Hz standard, other voltages available
6. Opening Speed Control - model 852-B (optional on 80 mm and smaller).

ORDERING INSTRUCTIONS

Refer to the order form and ordering instructions.

1. Single Chamber (106) or (206)
2. Solenoid Voltage
3. Energise or de-energise solenoid to close main valve.



Scan for more
information

Disclaimer: While every effort has been made to ensure that the information in this document is correct and accurate, users of Hygrade Water Infrastructure product or information within this document must make their own assessment of suitability for their particular application. Product dimensions are nominal only, and should be verified if critical to a particular installation. No warranty is either expressed, implied, or statutory made by Hygrade Water Infrastructure unless expressly stated in any sale and purchase agreement entered into between Hygrade Water Infrastructure and the user.

October 2024

+61 7 38059186
hygradewater.com.au

BRISBANE (Head Office) 42-44 Blue Eagle Drive, Meadowbrook, QLD 4131
SYDNEY 2/35 Prime Dr, Seven Hills NSW 2147, Australia
MELBOURNE 20A Frances Drive, Dandenong South 3175

HW **HYGRADE WATER**
INFRASTRUCTURE