

Pratt Plug Valves DN50-DN1400

Pratt Ballcentric[®] plug valves are designed for isolation and control duty in water, waste water, and other mediums with suspended solids.



TECHNICAL GUIDE: **VH7.1**

Applications

Waste Water

Abrasive Fluid

Isolation and flow control

Product Attributes

Design of the bonnet and stem allows for on-site adaption of gear operators, power actuators, or extension devices

Access to the body for cleaning or inspection does not require removal from the line

Stem seals can be easily replaced without removing the bonnet

Approvals/Standards

Ductile iron body to ASTM A-536-Grade 65-45-12

Flanges to AS4087 Fig. B5

Quality

ISO 9001:2015 Quality Management Systems

The Ballcentric[®] plug valves are designed to meet high standards for dependable performance with excellent features achieved by the utilisation of the very latest design and manufacturing techniques.

Product Attributes

- High integrity casting
- CNC manufacturing delivers consistent sizes on all components
- 99% nickel seat on DN80 and larger valves
- Stem seals can be easily replaced without removing the bonnet
- Access to the body for cleaning or inspection does not require removal from the line
- Design of the bonnet and stem allows for on-site adaptation of gear operators, power actuators, or extension devices on to standard valves
- DN80-1400 BS5163 face-to-face dimension

Applications

- Waste Water
- Abrasive Fluid
- Isolation
- Control/Modulating Duty
- Above Ground
- Buried Service
- Horizontal/ Vertical Installation

Standards

- DN80-1400 Flange to Flange dimensions to BS5163
- Ductile iron body & plug to ASTM A-536-Grade 65-45-12

Product Features

- **BODY**
Conforming to AWWA C517 wall thickness, the Ballcentric[®] plug valve body casting is in ASTM A-536-Grade 65-45-12 Ductile Iron using high pressure moulding techniques.
- **SEAT**
The Ballcentric[®] plug valve incorporates as standard, on DN80 and larger, a 1/8" thick welded 99% nickel seat for corrosion and erosion resistance specifically profiled for low torque and extended seat life.

- **STEM SEAL**

High integrity sealing by combining the advantages of a resilient and abrasion resistant U-Cup seal. From vacuum to high pressure, the self-adjusting sealing system (per AWWA C504) gives positive, trouble-free service and is retained independently of the plug stem or external torque device, thereby eliminating periodic maintenance.

- **BEARINGS**

The plug rotates in permanently lubricated 316 grade stainless steel bearings, located in the body and bonnet, along with upper and lower PTFE thrust washers, which ensure consistently low operating torque.

- **PLUG**

Supported on integral trunnions, the plug is totally encapsulated with an elastomer that is moulded on to the casting providing tight shut off even under vacuum conditions. High integrity corrosion-free sealing is achieved by a variety of abrasion resistant elastomers which protect the plug right up to the trunnions. When assembled, the light compression of the elastomers onto PTFE thrust washers, prevents entry of abrasive materials into the bearings.

- **BONNET SEAL**

Superior "O" ring sealing with metal / metal contact means lower bolting stresses compared with compression gaskets.

- **FLOW**

The port design (round on DN50 – 1400 and rectangular on DN350 and larger) with streamlined internal contours gives the highest industry capacity straight through flow in the full open position, reducing turbulence and pressure drop and the effect of erosive media. Handling of sludges and slurries is therefore enhanced.

- **INTERCHANGEABLE**

Because of the common face to face dimension (BS5163) with Resilient Seated Gate Valves in sizes DN80 – 1400, fitting the Ballcentric[®] plug valve into existing systems is accomplished without pipeline modifications.

- **TRAVEL STOPS**

Adjustable open and closed travel stops are fitted as standard on both wrench and gear operated Ballcentric[®] plug valves.

Stocked Version

- Sizes: DN50-1400
- Body: ASTM A-536 Grade 65-45-12 Ductile Iron
- Flanges: AS4087 Fig B5 Raised Face
- Operation:
 - DN50 & 80 Lever Operated
 - DN100-200 Above ground service gearbox
- Plug Coating: NBR
- Port:
 - DN50-1400 Round Port
- Seat:
 - DN50-65 Epoxy Coated Seat
 - DN80 and above 99% Nickel Welded Seat

TABLE 1 AS4087

Code	DN (mm)	Port	Flange	Lever or Gearbox
VPDF0504087L	50	Round	AS4087	Lever
VPDF0804087L	80	Round	AS4087	Lever
VPDF1004087G	100	Round	AS4087	Gearbox
VPDF1504087G	150	Round	AS4087	Gearbox
VPDF2004087G	200	Round	AS4087	Gearbox
VPDF2504087G	250	Round	AS4087	Gearbox
VPDF3004087G	300	Round	AS4087	Gearbox

Other plug valve models are available on request

- Specifications as per the stocked version except flanges AS2129 Table E and EN1092-2 for sizes DN50-1400.
- 80% Rectangular port valves DN350-1400+ also available.
- 100% Port configuration

TABLE 2 AS2129 Table E

Code	DN (mm)	Port	Flange	Lever or Gearbox
VPDF0502129EL	50	Round	AS2129 Table E	Lever
VPDF0802129EL	80	Round	AS2129 Table E	Lever
VPDF1002129EG	100	Round	AS2129 Table E	Gearbox
VPDF1502129EG	150	Round	AS2129 Table E	Gearbox
VPDF2002129EG	200	Round	AS2129 Table E	Gearbox
VPDF2502129EG	250	Round	AS2129 Table E	Gearbox
VPDF3002129EG	300	Round	AS2129 Table E	Gearbox

TABLE 3 EN1092-2

Code	DN (mm)	Port	Flange	Lever or Gearbox
VPDF0501092L	50	Round	EN1092-2	Lever
VPDF0801092L	80	Round	EN1092-2	Lever
VPDF1001092G	100	Round	EN1092-2	Gearbox
VPDF1501092G	150	Round	EN1092-2	Gearbox
VPDF2001092G	200	Round	EN1092-2	Gearbox
VPDF2501092G	250	Round	EN1092-2	Gearbox
VPDF3001092G	300	Round	EN1092-2	Gearbox

Plug Valve Operation

- Valve in closed position for bubble tight shut-off
- Normal flow direction gives pressure assisted sealing
- Torques are low even in reverse flow

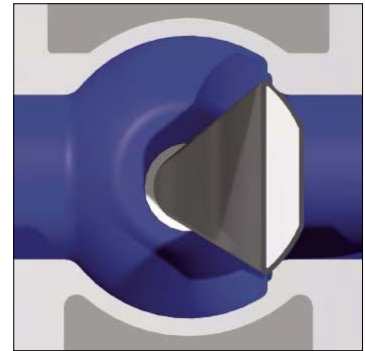

- Plug rotates away from the seat for instant opening
- Seat wear and operating torque reduced
- No further seat contact until valve is closed again

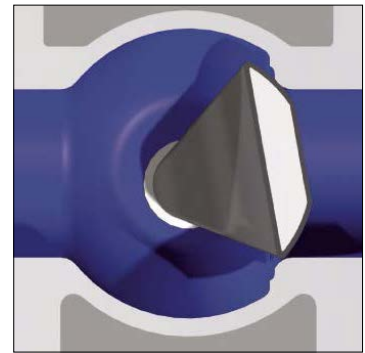

- Design of Ballcentric plug valve allows modulating control over the full 90° travel
- Ideally suited for balancing service
- Standard rotary valve provides control and tight shut off in one valve



- Plug is out of flow path when fully open
- Straight through, uninterrupted smooth flow
- Round port reduces turbulence and erosion, lowers pumping costs and can be "pigged" to clean the pipeline



Installation

The Ballcentric® plug valve is suitable for flow and shut-off in either direction. Seat end downstream is the preferred orientation and any reverse flow requirement should be stated at the time of order. For use on fluids with suspended solids, installation with the seat upstream and the valve stem horizontal is recommended with plug rotation to the top of the valve to ensure smooth operation.

In-Line Maintenance

In the unlikely event of gland leakage, the stem seals can be easily replaced without removing the bonnet. Access to the body for cleaning or inspection does not require removal from the line.

Modular Construction

Design of the bonnet and stem allows for on-site adaptation to gear operators, power actuators or extension devices on to standard valves. Conversion can be easily undertaken without removing the valve bonnet, thereby minimising downtime.

Power Operation

Pneumatic, electric, or hydraulic operation is available, complete with accessories such as limit switches, solenoid valves and positioners when required.



Installation Options

The type of materials carried in the pipeline and the location the valve determine the correct installation orientation:

LIQUIDS WITHOUT SUSPENDED SOLIDS

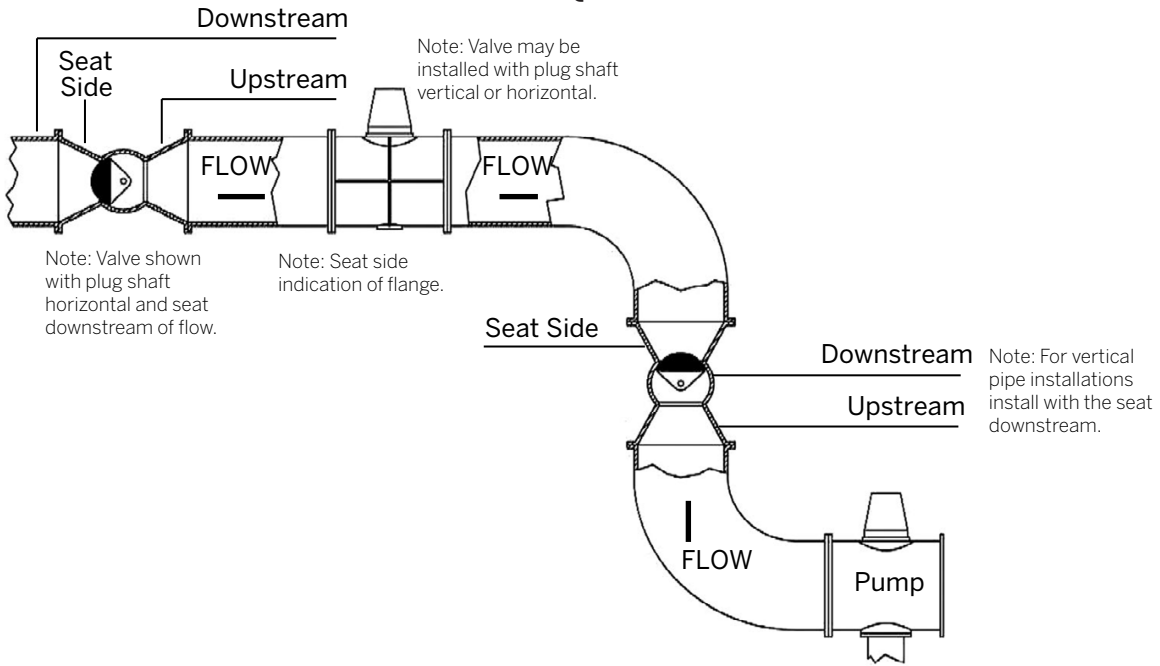

SUSPENDED SOLIDS AND DIRTY GASES

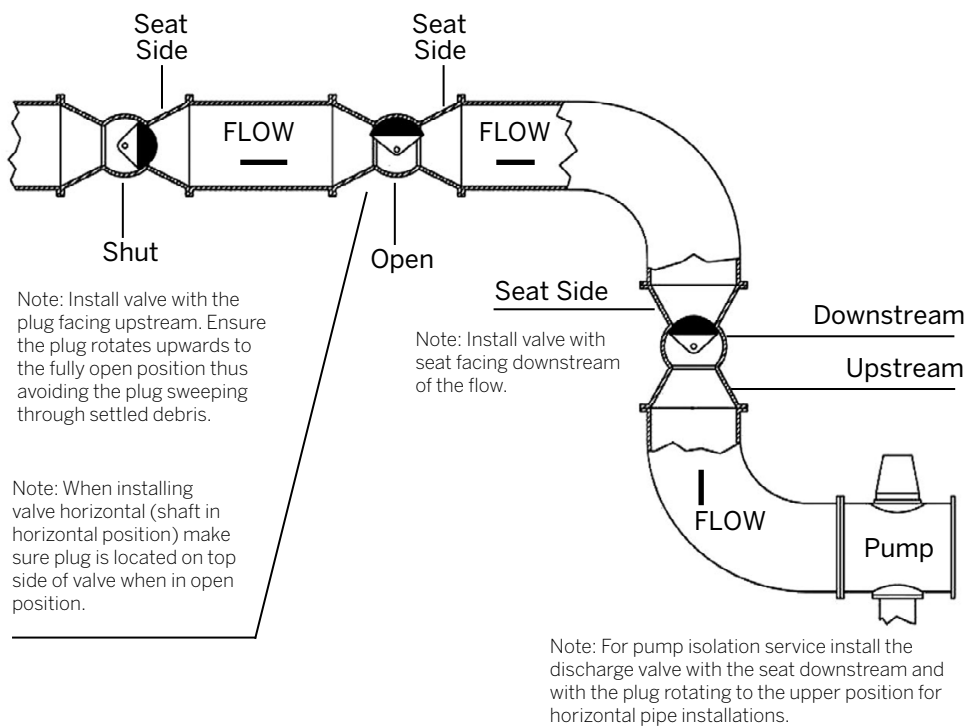

Flanged End - AS4087 PN10/16

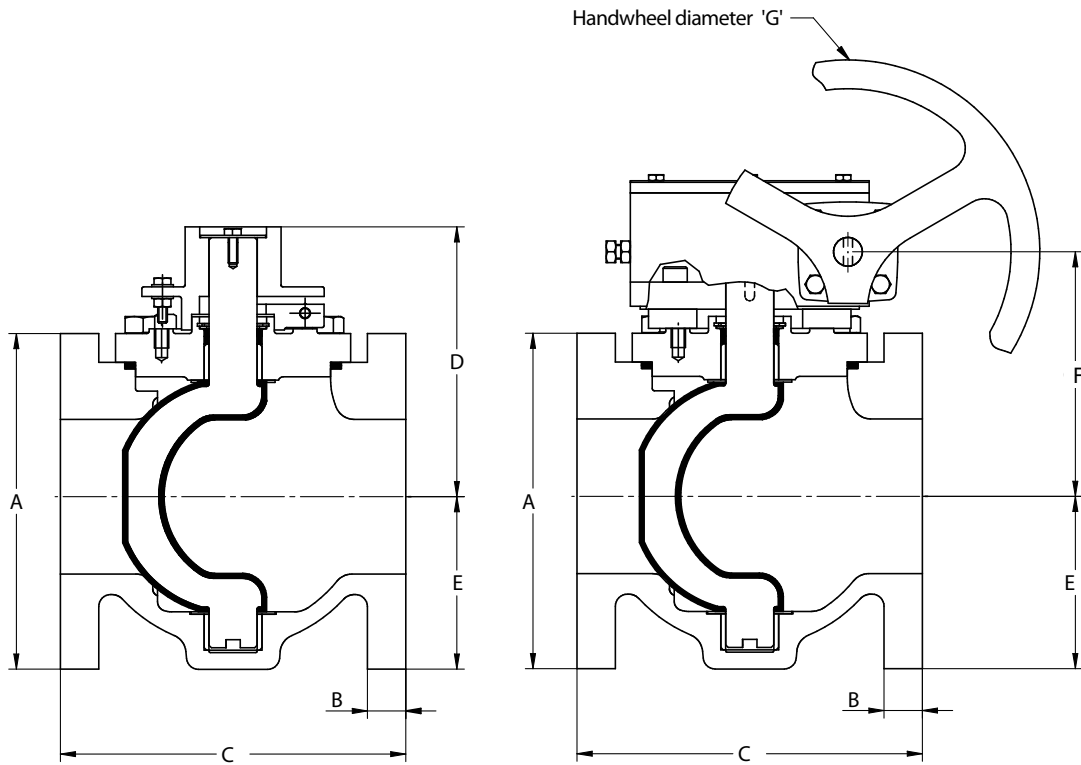





TABLE 4 Flanged End - AS4087 PN10/16

Code	Nominal Valve Size (DN)	A	B	C	D	E	F	G	Weight approx. (kg)
VPDF0504087L	50	166	17	180	130	88	-	-	11
 VPDF0804087L	65	178	20	191	157	89	137	152	14
VPDF0804087L	80	191	22	203	157	95	142	152	18
VPDF1004087G	100	229	24	229	184	114	160	152	32
 VPDF1254087G	125	254	26	254	211	146	192	152	48
VPDF1504087G	150	279	26	267	213	146	192	152	52
VPDF2004087G	200	343	30	292	271	194	245	305	86
VPDF2504087G	250	406	32	330	305	226	295	305	156
VPDF3004087G	300	483	32	356	350	254	338	305	200

Note:

 = Items available on indent order only
Threaded bolt holes are M20

Flanged End - Fig.601 - PN10/16

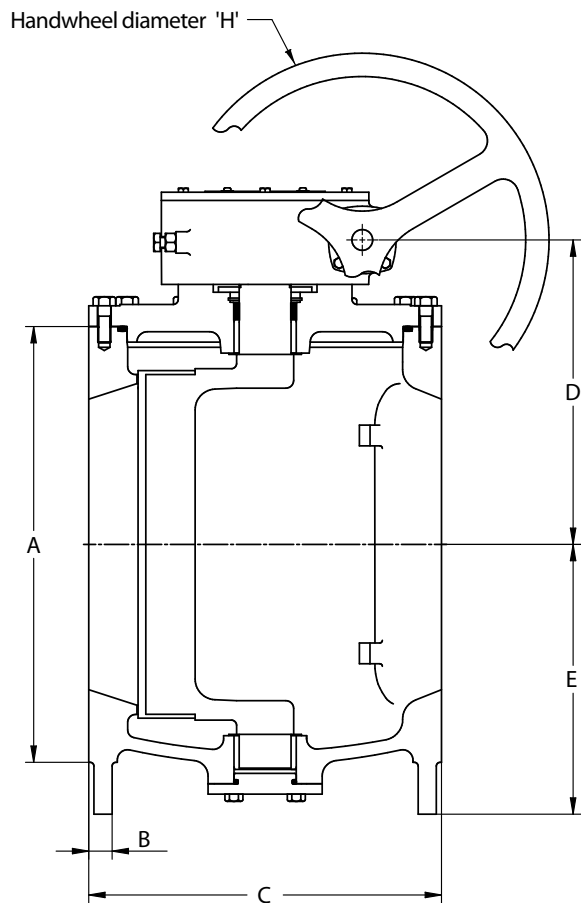

VH7.1 PRATT PLUG VALVE | PIPE & PIPE FITTINGS | PG 8

TABLE 6 Flanged End Fig.601- PN10/16

Code	Nominal Valve Size (DN)	A	B	C	D	E	H	Weight approx. (kg)
	350	533	35	432	383	330	457	411
	400	591	36	451	402	356	457	467
	450	635	40	546	432	381	457	615
	500	699	43	597	519	406	457	853
	600	813	48	1067	581	549	610	1724
	700	984	54	1295	701	629	610	2359
	800	984	54	1295	701	629	610	2359
	900	1168	60	1524	838	737	610	3153
	1000	1346	67	1829	956	737	762	4609
	1200	1511	70	2134	956	914	762	6056
	1400	1683	76	2438	956	914	762	6849

= Items available by indent order only

Materials of Construction

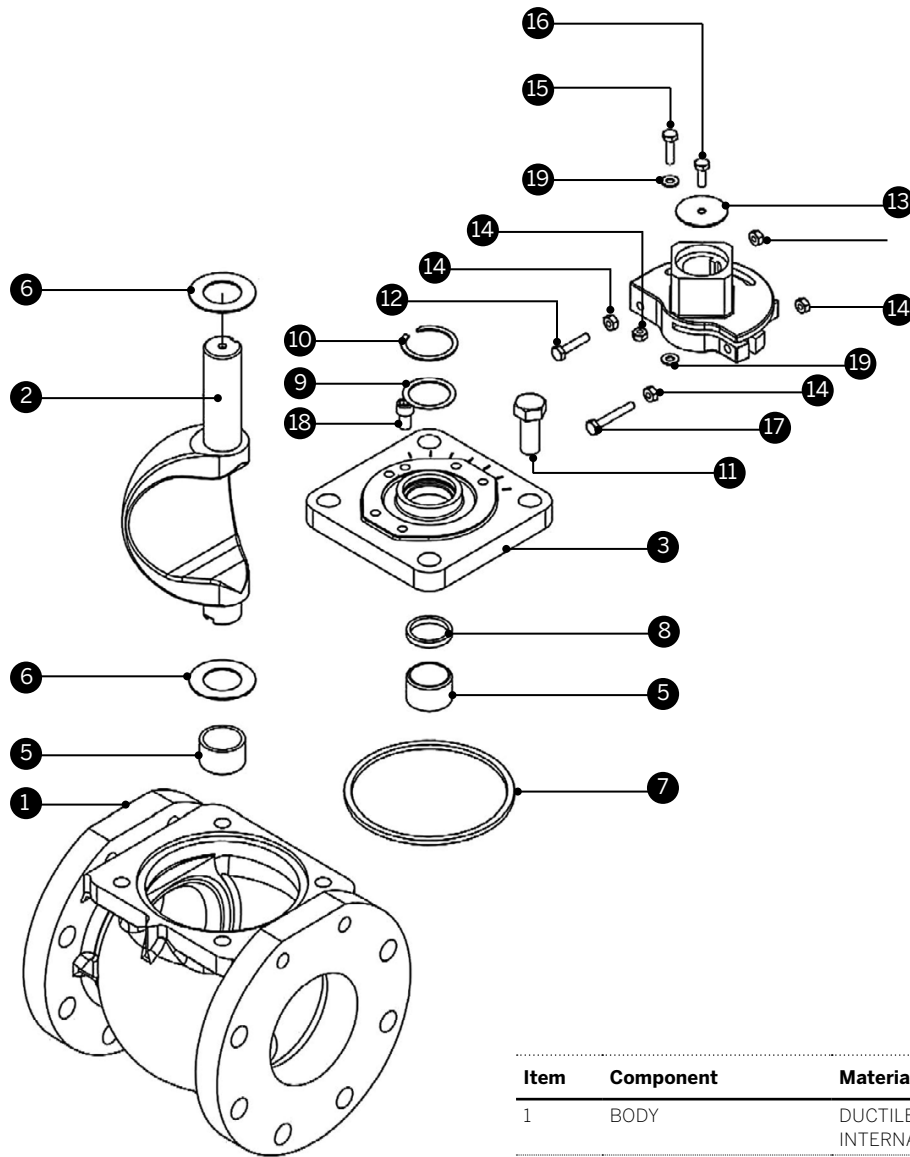

Item	Component	Material
1	BODY	DUCTILE IRON ASTM A536 FBE COATED INTERNALLY AND EXTERNALLY
2	PLUG	DUCTILE IRON ASTM A536 RUBBER COATED
3	COVER	DUCTILE IRON ASTM A536 FBE COATED INTERNALLY AND EXTERNALLY
4	TORQUE COLLAR	DUCTILE IRON ASTM A536
5	JOURNAL BEARING	ST STEEL - ANSI 316
6	THRUST WASHER	PTFE
7	O RING	RUBBER AS PLUG
8	U CUP SEAL	RUBBER AS PLUG
9	WASHER	BRASS- ASTM B-138-675
10	SNAP RING - INTERNAL	SPRING STEEL
11	CLOSED STOP	316 STAINLESS STEEL
12	LOCKING WASHER	316 STAINLESS STEEL
13	NUT	316 STAINLESS STEEL
14	OPEN STOP	316 STAINLESS STEEL
15	SETSCREW	316 STAINLESS STEEL
16	SETSCREW	316 STAINLESS STEEL
17	TORQUE BOLT	316 STAINLESS STEEL
18	TRAVEL STOP	316 STAINLESS STEEL
19	WASHER	316 STAINLESS STEEL

Elastomers available for Ballcentric® Valve

- Nitrile

A general purpose material sometimes referred to as BUNA-N or HYCAR with a -10°C to 100°C temperature range. Used on sewage, water, hydrocarbon and mineral oils.

- EPDM

An excellent polymer for use on chilled water through to LP steam applications having a temperature range of -10°C to 120°C. Resistance to many acids, alkalies, detergents, phosphate esters, alcohols and glycols is an added benefit.

- Neoprene

This versatile material shows outstanding resistance to abrasion and ozone. Chemical resistance to a wide range of petroleum-based products and dilute acids and alkalies. Temperature range -10°C to 100°C.

- Viton

Retention of mechanical properties at high temperature is an important feature of this elastomer: temperature range is -10°C to 200°C. It also has excellent resistance to oils, fuels, lubricants and most mineral acids and aromatic hydrocarbons.

Note: Natural rubber is also available.

TABLE 8

SIZES	DRILLING	PRESSURE
DN300 and smaller	PN16	16 bar
DN350 to DN600	PN16	16 bar
DN300 and smaller	PN25	25 bar
DN350 to DN500	PN25	16 bar
DN600 and larger	PN25	10 bar

Note:

Body Hydrotest = 1.5 x rated pressure

Seat Test = 1.1 x rated pressure

Elastomer Selection Chart

The chart below is to assist in the selection of elastomers for some common fluids. It doesn't mean other elastomers are not suitable within varying limits. Temperature, concentration, and mixture all affect chemical attack. If there is any doubt regarding compatibility, specific conditions should be referred to engineering for recommendations. The chart below is to serve as a guide only.

Note: Suitability of an elastomer for a particular service does not necessarily indicate that the pressure envelope material is suitable.

TABLE 9 Elastomer Selection Chart

Service	Elastomer	Average Useful Temp Range	Service	Elastomer	Average Useful Temp Range	Service	Elastomer	Average Useful Temp Range
Acetone	EPDM	10°C to 120°C	Caustic Soda	EPDM	10°C to 120°C	Oil Animal	Nitrile	10°C to 100°C
Air	EPDM	10°C to 120°C	Cement Slurry	EPDM	10°C to 120°C	Oil Mobil Therm Light	Viton	10°C to 200°C
Air w/ Oil	Nitrile	10°C to 100°C	Copper Sulphate	EPDM	10°C to 120°C	Oil Mobil Therm 600	Viton	10°C to 200°C
Alcohol, Amyl	EPDM	10°C to 120°C	Creasote (Coal)	Nitrile	10°C to 100°C	Oil Mobil Therm 603	Nitrile	10°C to 100°C
Alcohol, Aromatic	Viton	10°C to 200°C	Coal Slurry	Nitrile	10°C to 100°C	Oil Lubricant	Nitrile	10°C to 100°C
Alcohol, Butyl	Neoprene	10°C to 100°C	Diesel Fuel No.1	Nitrile	10°C to 100°C	Oil Vegetable	Nitrile	10°C to 100°C
Alcohol, Denatured	Nitrile	10°C to 100°C	Diethylene Glycol	EPDM	10°C to 120°C	Paint Latex	Nitrile	10°C to 100°C
Alcohol, Ethyl	EPDM	10°C to 120°C	Ethylene Glycol	EPDM	10°C to 120°C	Phosphate Ester	EPDM	10°C to 120°C
Alcohol, Grain	Nitrile	10°C to 100°C	Fatty Acid	Nitrile	10°C to 100°C	Propane	Nitrile	10°C to 100°C
Alcohol, Isopropyl	Neoprene	10°C to 100°C	Fuel Oil No. 2	Nitrile	10°C to 100°C	Rape Seed Oil	EPDM	10°C to 120°C
Alcohol, Methyl	EPDM	10°C to 120°C	Fertilizer Liquid (H4N2O2)	EPDM	10°C to 120°C	Sewage (w/oils)	Nitrile	10°C to 100°C
Ammonia, Anhydrous	Neoprene	10°C to 100°C	Gasoline Keg	Nitrile	10°C to 100°C	Sodium Hydroxide 20%	EPDM	10°C to 120°C
Ammonium, Nitrate	EPDM	10°C to 120°C	Gas Natural	Nitrile	10°C to 100°C	Starch	EPDM	10°C to 120°C
Ammonia, Water	EPDM	10°C to 120°C	Glue Animal	Nitrile	10°C to 100°C	Steam 149/C	EPDM	10°C to 120°C
Animal Fats	Nitrile	10°C to 100°C	Green Liquor	EPDM	10°C to 120°C	Stoffard Solvent	Nitrile	10°C to 100°C
Black Liquor	EPDM	10°C to 120°C	Hydraulic Oil	Nitrile	10°C to 100°C	Sulphuric Acid 10%50%	Neoprene	10°C to 100°C
Blast Furnace Gas	Neoprene	10°C to 100°C	Hydrogen	Nitrile	10°C to 100°C	Sulphuric Acid 100%	Viton	10°C to 200°C
Butane	Nitrile	10°C to 100°C	JP4 JP5	Viton	10°C to 200°C	Trichloroethylene Dry	Viton	10°C to 200°C
Bunker Oil "C"	Nitrile	10°C to 100°C	Kerosene	Nitrile	10°C to 100°C	Triethanol Amine	EPDM	10°C to 120°C
Calcium Chloride	EPDM	10°C to 120°C	Ketone	EPDM	10°C to 120°C	Varnish	Viton	10°C to 200°C
Carbon Dioxide	EPDM	10°C to 120°C	Lime Slurry	EPDM	10°C to 120°C	Water, Fresh	EPDM	10°C to 120°C
Carbon Monoxide (Cold)	Neoprene	10°C to 100°C	Methane	Nitrile	10°C to 100°C	Water, Salt	EPDM	10°C to 120°C
Carbon Monoxide (Hot)	Viton	10°C to 200°C	Methyl Ethyl Ketone	EPDM	10°C to 120°C	Xylene	Viton	10°C to 200°C
Carbon Tetrachloride	Viton	10°C to 200°C	Naptha (Berzin)	Nitrile	10°C to 100°C			



Scan for more
information

Disclaimer: While every effort has been made to ensure that the information in this document is correct and accurate, users of Hygrade Water product or information within this document must make their own assessment of suitability for their particular application. Product dimensions are nominal only, and should be verified if critical to a particular installation. No warranty is either expressed, implied, or statutory made by Hygrade Water unless expressly stated in any sale and purchase agreement entered into between Hygrade Water and the user.

January 2023

0800 494 723
hygradewater.co.nz

102 Neilson Street
Onehunga, Auckland 1061, New Zealand
PO Box 58142, Botany, Auckland 2163

