

F-Type 4 Modulating Float Valve

The Singer® model F-Type 4 modulating float valves are ideal for balancing the inflow and outflow demand into the reservoir and maintaining level at the designated maximum.



TECHNICAL GUIDE: **AVH1.24**

Applications

Potable water
Tank level control
Municipal
Mining Applications
Irrigation Applications

Product Attributes

Maintains relatively constant level
Automatic compensation for level draw-down
Standard integral damping reduces hunting
Drip-tight at high level shut-off
Low supply pressure options

Approvals/Standards

AS 5081:2008
Flanges to AS/NZS4087 Fig. B5
Coating complies with AS/NZS 4158

Quality

ISO 9001:2015 Quality Management Systems



Licence Number:
WMK/SMK26726

The valve closes drip-tight at the maximum level and modulates to maintain the tank level. The float pilot is remotely installed at the high level in the reservoir tank. Pilot connections to the main valve are connected in the field. As the reservoir level drops the main valve is opened proportionally to increase the filling rate. Movement of the main stem alters the size of the closing restriction, interrupting the tendency of the valve to hunt.

STANDARD MATERIALS

Standard materials for pilot system components are:

- Stainless Steel
- Plastic Float
- Brass, Copper, Iron

The stilling well and the connections between the main valve and the R-400 pilot are provided by others.

SELECTION SUMMARY

1. Generally, select line size to minimise losses during normal forward flow.
2. Use the performance curves and sizing bulletin to check the pressure drop across the valve at normal flow rate.
3. Check the maximum operating pressure against the maximum working pressure rating of the flanges.
4. If the outlet pressure is less than 35% of the inlet pressure, check for cavitation.

TYPICAL APPLICATION

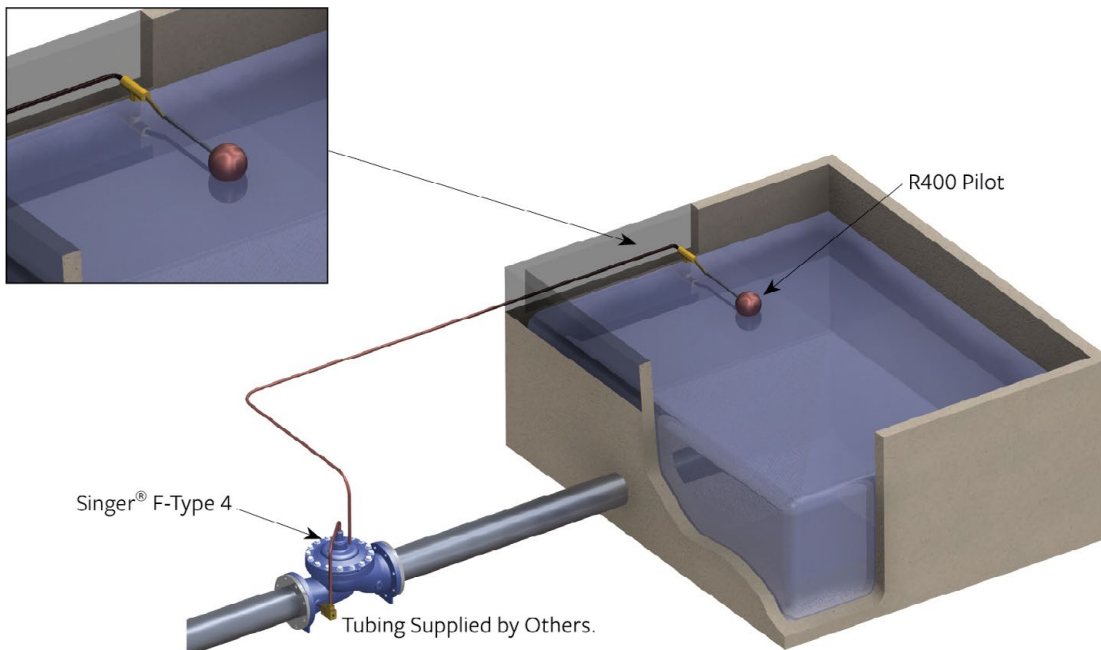

5. If the inlet pressure is less than 0.7 bar higher than the maximum reservoir head, consult with us.

6. Assisted opening may be required for full flow.

- *For non-modulating (on-off) service, refer to model 106-F-Type 5 or 206-F-Type 5.*
- *For high tower reservoir, refer to models 106-A-Type 1 / 106-A / 206-A Type 1,2,3 or 4 Altitude Control Valves.*

ORDERING INSTRUCTIONS

Refer to the order form and ordering instructions. Additionally, include the following information for this product.

1. Single chamber (106) or (206)

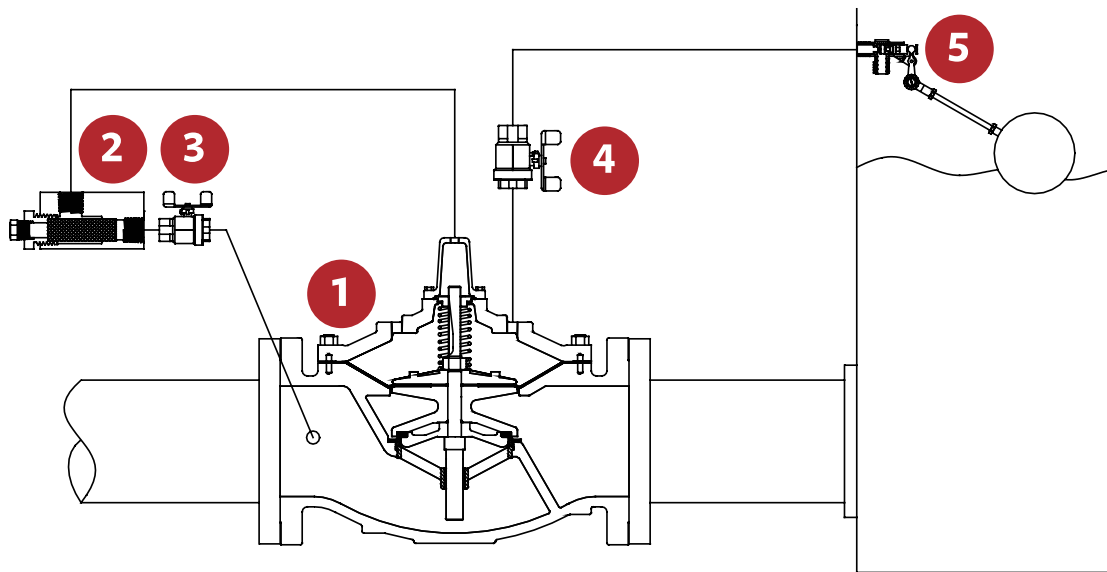

 SCHEMATIC A-0608D

SCHEMATIC DRAWING

7. Main Valve - 106-PG, or 206-PG, Internal Needle Stem Valve (INSV) Built Into Stem.
8. Strainer - 40 Mesh Stainless-Steel Screen
9. Isolation Valve
10. Isolation Valve
11. R400 Float Pilot Comes with Plastic Float

Note: Schematic shown for 65 mm and larger. For 50 mm and smaller, refer to Schematic A-0399C.

TABLE 1 106-RF and 206-RF Flow Coefficient Cv

Size (mm)	106-F-Type 4		206-F-Type 4	
	Max Continuous (L/s)	Pressure drop (Bar)	Max Continuous (L/s)	Pressure drop (Bar)
15mm	0.8	1.4	-	-
19mm	1	1.4	-	-
25mm	3	1.4	-	-
32mm	6	1	-	-
40mm	8	1	-	-
50mm	13	1.4	-	-
65mm	19	1	-	-
80mm	29	1.1	19	1.3
100mm	50	1	37	1
150mm	114	1	65	1.2
200mm	196	1	145	1.4
250mm	309	1	260	1.2
300mm	442	1.1	404	1.2
350mm	536	0.8	-	-
400mm	694	1.2	582	1.2
450mm	-	-	1040	1.6
500mm	1104	0.6	1040	1.5
600mm	1577	0.7	-	-
600 x 400mm	-	-	1040	1.4
600 x 500mm	-	-	1370	1.4
700mm	-	-	2120	1.2
750mm	-	-	2123	1.2
800mm	-	-	2126	1.2
900mm	3500	0.6	2132	1.2
1000mm	-	-	3500	1.2
1200mm	-	-	3500	1.2

** $K_v = L / s$ at 1 bar pressure drop

($Q = K_v \sqrt{\Delta P}$)

Note: Based on fully open valve



Scan for more information

Disclaimer: While every effort has been made to ensure that the information in this document is correct and accurate, users of Hygrade Water Infrastructure product or information within this document must make their own assessment of suitability for their particular application. Product dimensions are nominal only, and should be verified if critical to a particular installation. No warranty is either expressed, implied, or statutory made by Hygrade Water Infrastructure unless expressly stated in any sale and purchase agreement entered into between Hygrade Water Infrastructure and the user.

January 2025

+61 7 38059186
hygradewater.com.au

BRISBANE (Head Office) 42-44 Blue Eagle Drive, Meadowbrook, QLD 4131
SYDNEY 2/35 Prime Dr, Seven Hills NSW 2147, Australia
MELBOURNE 20A Frances Drive, Dandenong South 3175

HW HYGRADE WATER
INFRASTRUCTURE